



Rollersport, Inc.

Vintage Track Plans

(circa 1948-1969)

Introduction

The following drawings and instructions are plans for a Roller Derby track– the design now being obsolete. The tracks that were constructed from these plans cost approximately \$20,000 thirty years ago. We, Rollersport, Inc., are providing these plans, free of charge, to the general public primarily as a souvenir to those interested in the historical aspect of Roller Derby. Whereas an individual may construct a Roller Derby track from these instructions, advances in engineering, technology, and construction materials render the original plans unnecessarily expensive, cumbersome, and dated.

Regards,

Rollersport, Inc.

TOOLS

Amount	Item	Cost
4 each	long Yankee ratchet screwdrivers	\$140.00
6 each	Box-end wrenches 9/16" x 1/2"	\$30.00
6 each	Open-end wrenches 9/12" x 1/2"	\$30.00
6 each	Long sockets 9/16"	\$20.00
6 each	Deep sockets 1/2"	\$20.00
2 each	Drift Pins for slotted steel 3/8" holes	\$14.00
2 each	7 1/4" Skill saws	\$100.00
2 each	100' extension cords (H.D.)	\$36.00
2 each	3/8" Reverse screw guns	\$160.00
2 each	3/8" Reverse drill motors	\$55.00
3 each	Measuring tapes 1/12' - 1/25' - 1/100'	\$15.00

1 each	Large tool box (on wheels)	check price
2 each	Vice grips (clamp type)	\$17.00
1 each	Single jack (2#) hammer (no claw)	\$20.00
1 each	Heavy ball pin hammer	\$11.00
1 each	Cross cut hand saw	\$15.00
4 each	Counter sinker with pilot hole drill	\$15.00
1 each	Hack saw	\$8.00
1 each	Large square	\$15.00
2 each	1/2 horsepower Impact guns for elevator bolts	\$180.00
	Assorted drill bits for 5/16" with 3/8" clearance	\$10.00

NOTE: There is a need for a Table Saw and Radial Arm Saw when building tracks.

DEXION SLOTTED STEEL

CONVERSION GUIDE

When using the New Interlake diamond pattern, measure from diamond to diamond or arrow to arrow in order to line-up holes for bolting. All Dexion (angle iron) must be fed into the Interlake Cutter in the same manner.

EXAMPLE:

- a. The 3" side will always be to the RIGHT and the 1 ½" will be to the LEFT.
- b. If using the #260/144 Dexion Slotted Angle Iron. The pattern for holes are different- the size is 2.60" x 1.75". These measurements will replace the 1 ½" that are above.

INITIAL ASSEMBLY OF NEW TRACK

- Start at first straight-away section and erect in a counter clock-wise direction. Assemble seven (7) straight-away sections, proceed to turns NOT leaving bastard section #1 OPEN, instead place a regular turn section into space to maintain the six foot gap along the outer edge. Finish the turn sections until there is a PARALLEL ALIGNMENT to the opposite side of the track where straight-aways end and turns begin.

IMPORTANT – IMPORTANT – IMPORTANT

Floor must be marked with chalk lines before any construction begins, in order to maintain the **CORRECT ALIGNMENT**.

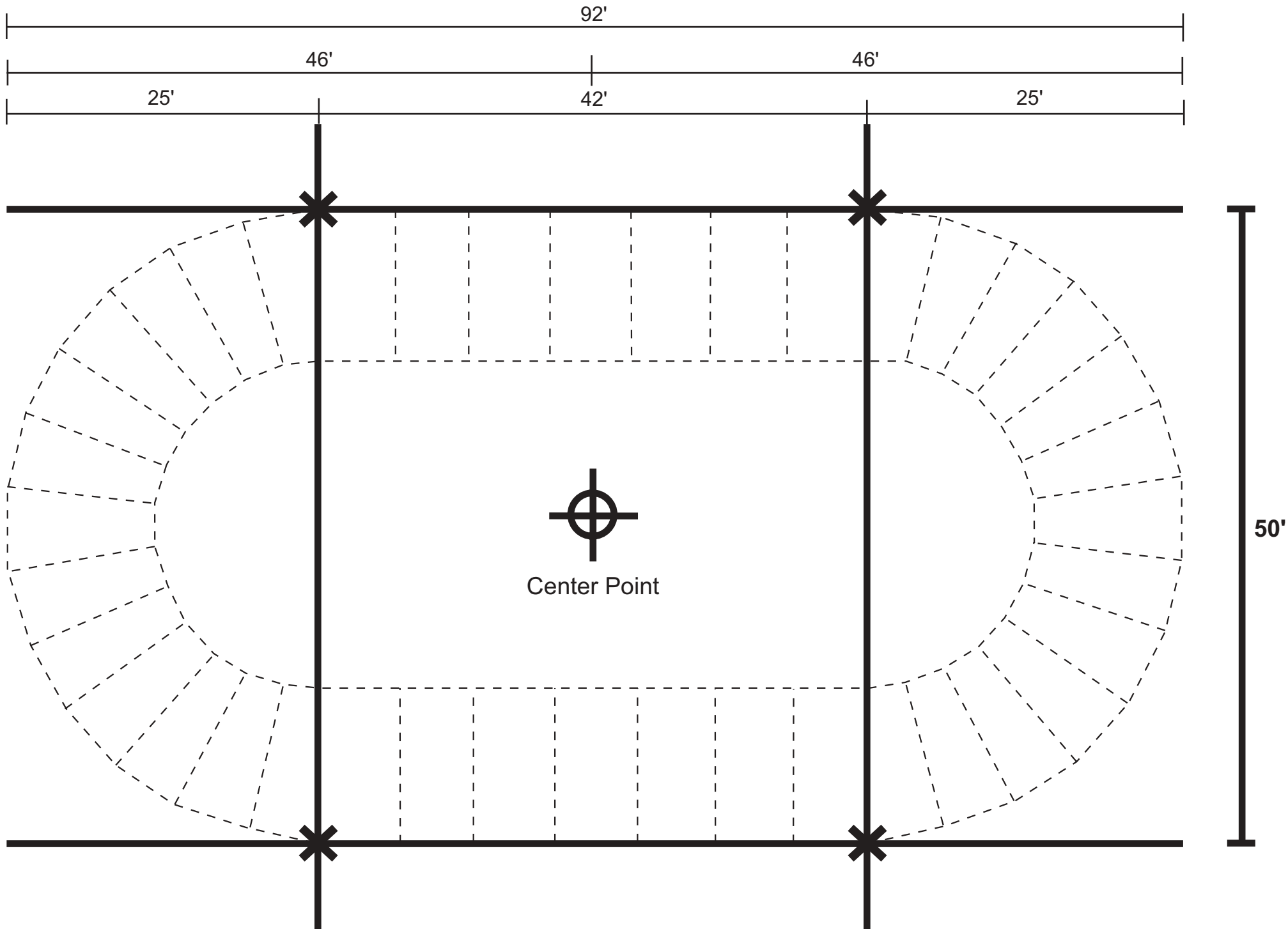

CENTER POINT & CHALK LINES

CONSTRUCTING TRACK SECTIONS

- Cut wood blocks (pads), drill holes, attach Dexion brackets.
- Cut all Steel and Uprights and attach Dexion brackets. (match hole patterns)
- Cut Plywood, Masonite, Handrails and Kick-rails.
- Drill holes in plywood and place elevator bolts.
 - a. 13 bolts in top pieces.
 - b. 17 bolts in middle pieces.
 - c. 13 bolts in bottom pieces.
- Flip-over and attach Dexion with washer and lock-nut using impact gun.
- Install Stiffners. (4 each)
- Stand on side and place aside.
- **START WITH THIS PROCEDURE AND REPEAT AGAIN AND AGAIN, UNTIL ALL SECTIONS ARE COMPLETED.**

SLOTTED STEEL PLACEMENT

Slotted steel Uprights must be placed with the 3" side between Track Sections and the 1 ½" side to the LEFT.

Straight-away

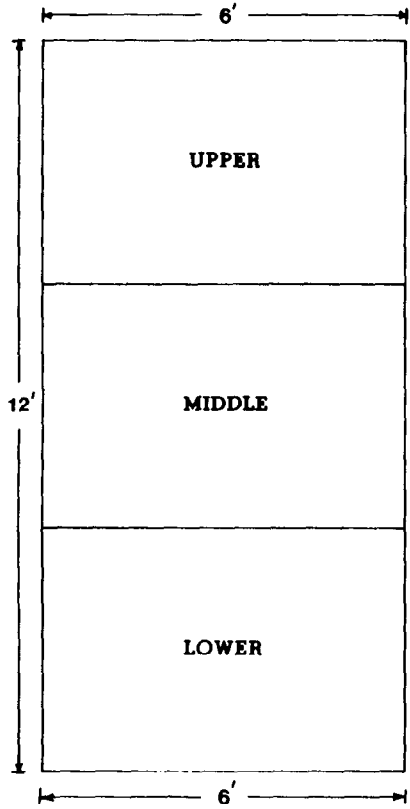

Bastard

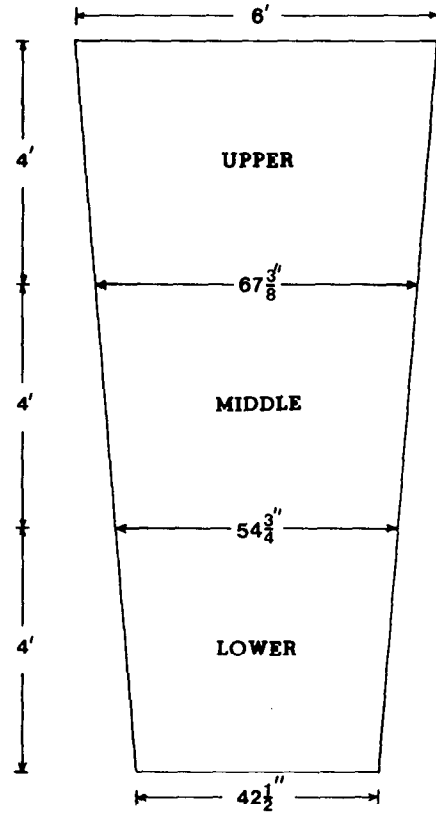

Turn

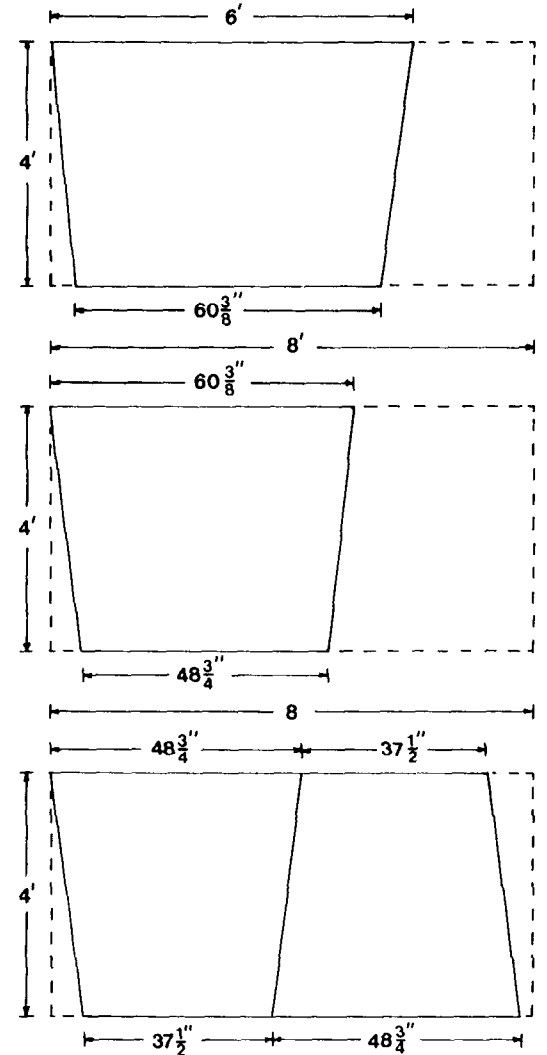
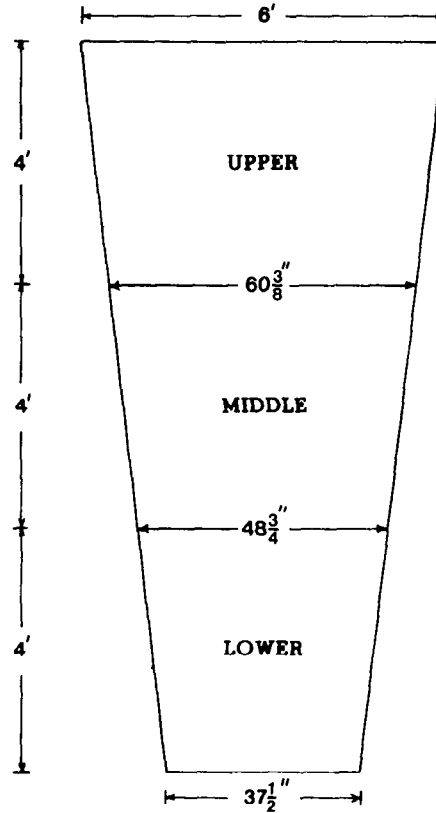

PLYWOOD

Cutting and Layout

Straightaway

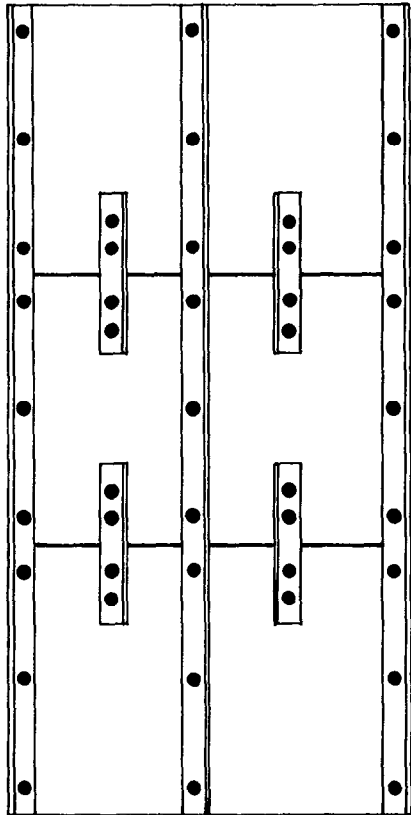

Underside View

Turn

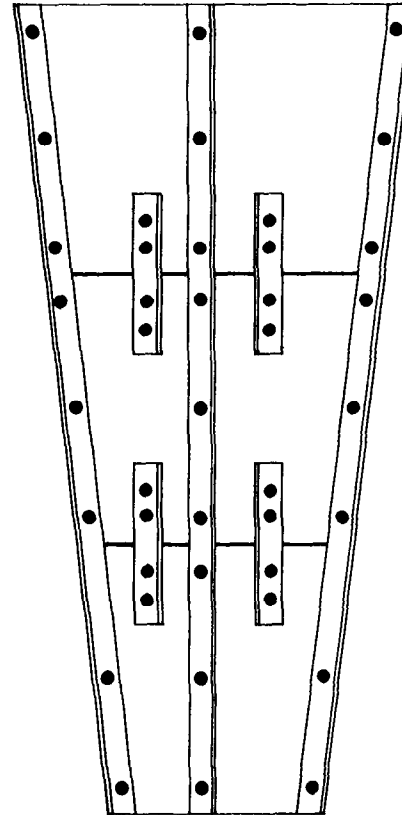

Underside View



End View

DEXION & CARRAGE BOLTS

Straightaway

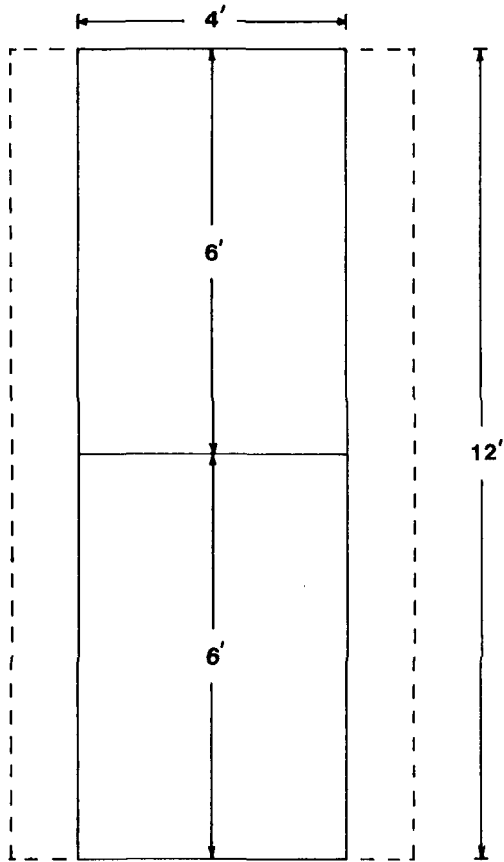

Bastard

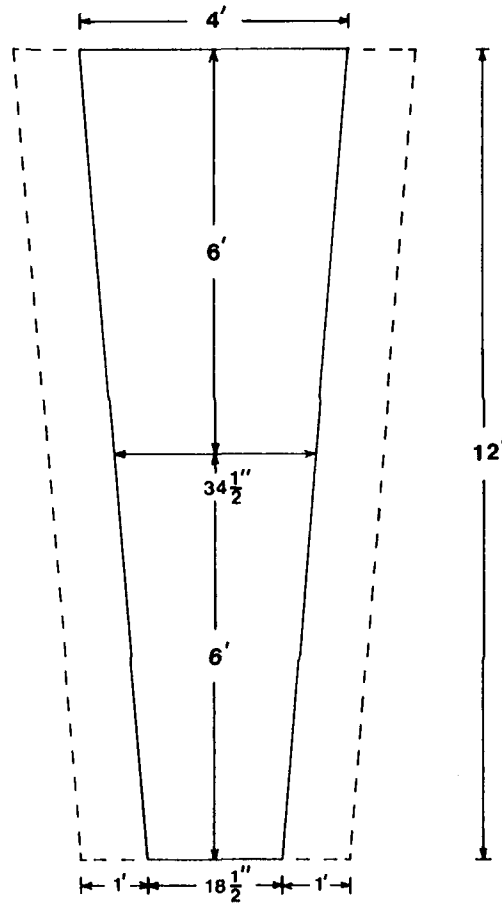

Turn

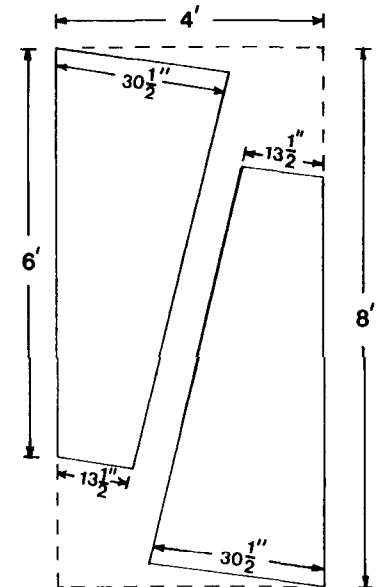
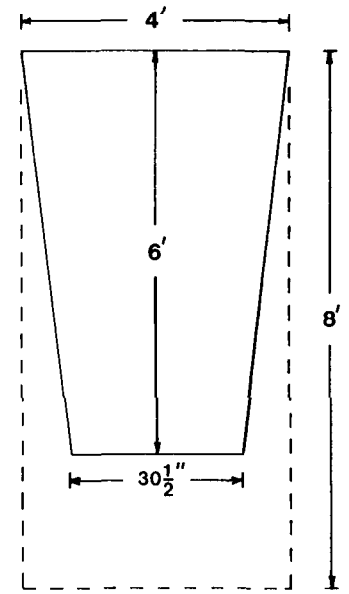
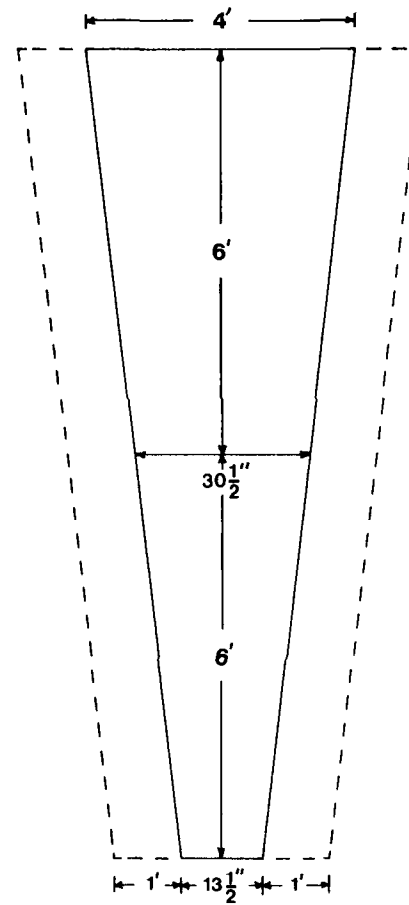

MASONITE

Cutting and Layout

CONSTRUCTION SET-UP

- Find your placement center point.
- Measure from this center point (**half the width**) of the track where the outside straight-away edge will be located.
- Measure from placement center (**half the length**) of the track where the outside edge will be located.
- From where these outer edges intersect, measure twenty-five (25') feet, this is where the first straight-away and turn SECTIONS meet.
- Make sure to lay out all track sections **BACK FAR ENOUGH** as not to get in the way when track is being erected.
- With the completion of measurements for the track set-up, lay out all track sections in order, and by number, along with up-rights, handrails, intermediates, and masonite. If the track was loaded in truck properly, it can be erected as the track sections are unloaded off the truck.
- If **ROAD CARTS** are being used, a great deal of time can be saved in the lay-out, and erecting the track.
- Check **NUMBERS** carefully in the lay out. Most important to **DOUBLE CHECK** again as the track is being erected.

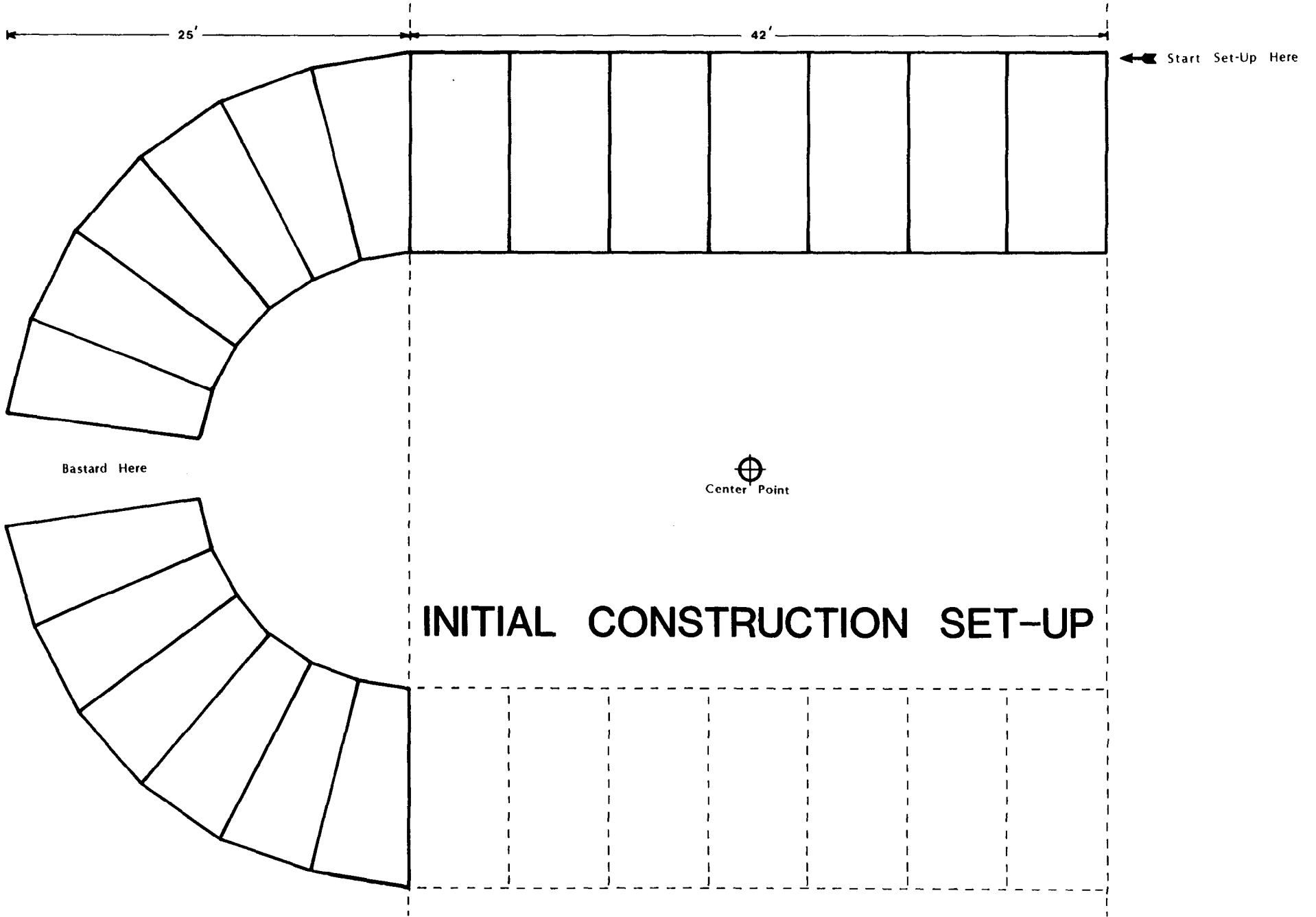

Bastard Here

Center Point

INITIAL CONSTRUCTION SET-UP

Start Set-Up Here

NORMAL PROCEDURE IN SETTING UP TRACK

TRACK SET-UP

- a. Start at section #10 in the middle of the straight-away.
- b. Proceed in a counter clock-wise direction.

FOUR PEOPLE

- c. One at each corner of track section marked #10 & #11.
- d. Lift section into place.

FIFTH PERSON

- e. Installs #10 Upright to side of track section (where marked #10).
- f. Places and tightens Nut & Bolt (finger tight).
- g. Fifth person then proceeds to the opposite side of the track section where marked #11 (as the four men are still holding up this section).
- h. Placing second upright #11 into position, inserting bolt only.
- i. Once bolt is inserted into marked position, the four people then lower this first track section to the floor.
- j. Moving counter clock-wise to the second track section marked #11 & #12.
- k. Lifting second section into position, placing carefully against the first section (where fifth person remained to steady first track section by holding #11 Upright steady, now places Nut and Bolt into marked hole, securing and connecting both sections.
- l. Fifth person again moves to the opposite side of second track section and lifts #12 Upright into position.
- m. This procedure will be repeated until the track has been fully erected.

SIXTH PERSON

- Follows and places upright braces in proper position, installs nut and bolt in hole where marked, then tightens.

SEVENTH PERSON

- Will place wood blocks under Dexion in the infield, along with installing nut and bolt, plus tighten.

EIGHTH PERSON

- (on creeper) will install center nut and bolt under track, plus tighten. This person will also check to make sure that all track sections fit snugly.
- Once track sections are up, the first four persons will be assigned to attaching handrails.

FIFTH AND SIXTH PERSON

- Will place temporary Masonite into position on track sections. All personnel will help in screwing down these Masonite pieces.

PADS

- Will be placed on Up-rights and handrails.

TARPAULIN

- Will be applied to the outer side of the track as the final touch to completing the track set-up

FINAL INSPECTION

- The Crew Chief and one member of his crew, using a check list will make a final inspection of the following:
 - a. HANDRAILS
 - b. INTERMEDIATES
 - c. INTERMEDIATE BRACES
 - d. UP-RIGHT BRACES
 - e. CENTER BOLTS UNDER TRACK
 - f. MASONITE SCREWED DOWN
 - g. HANDRAIL AND UP-RIGHT PADS

CHECK EVERYTHING – CHECK EVERYTHING – CHECK EVERYTHING

and

- DOUBLE CHECK EVERYTHING -

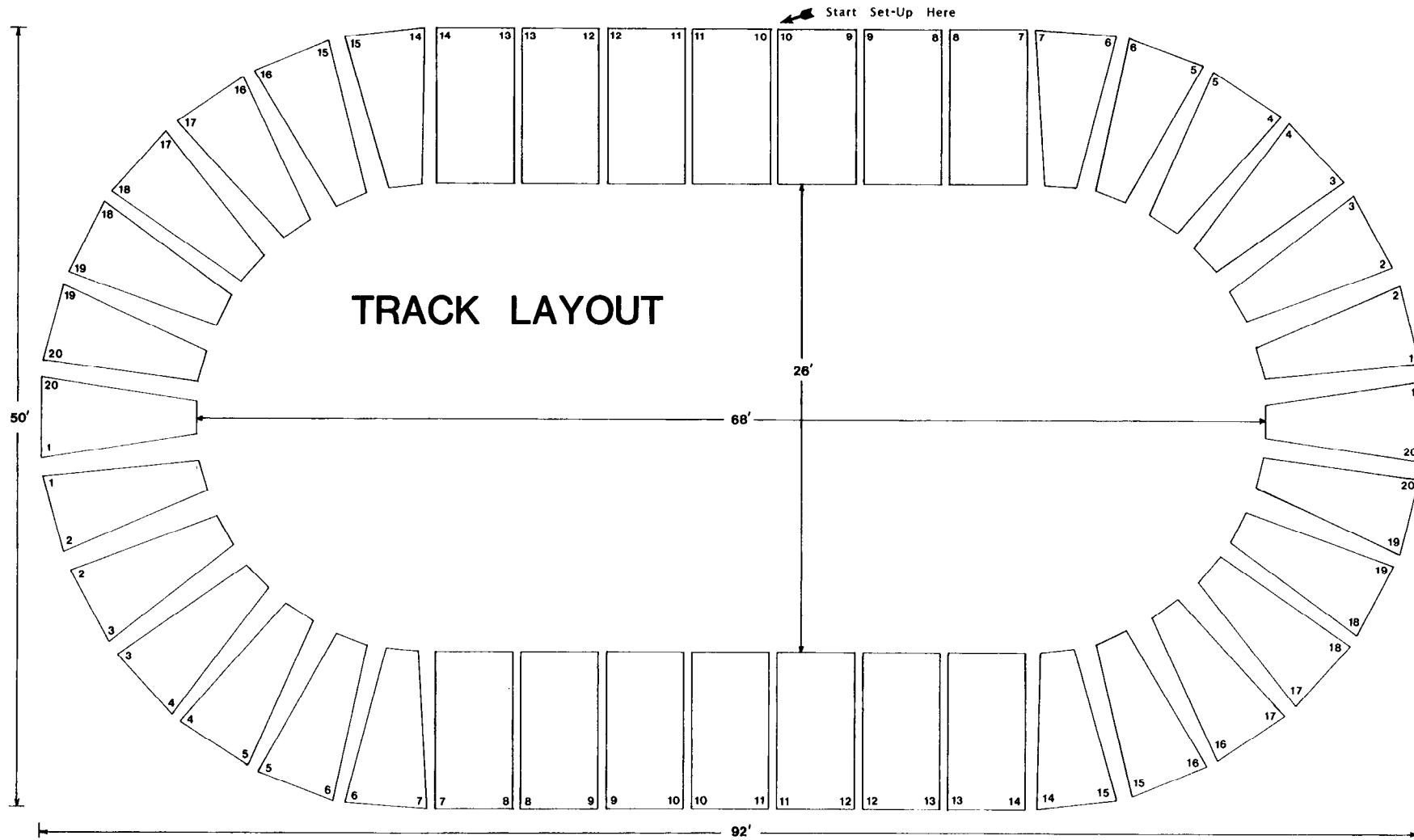

UP-RIGHTS – UNDERSIDE INTERMEDIATES – BRACES

TRACK SECTIONS

10 each – Turn sections

14 each – Straight-away sections

DEXION STEEL – Consists of 20 each 12' pieces

TOTAL AMOUNT OF DEXION PACKS are 18 + 2 packs for extra parts and any mistakes in cutting during construction.

INTERMEDIATES

12 each – 72"

4 each – 69"

4 each – 66"

4 each – 63"

4 each – 60"

4 each – 57"

4 each – 54"

4 each – 51"

TOTAL OF 40 pieces (two 12' packs of Dexion – 20 pieces in each pack).

NOTE:

- After Uprights and 12' Undersides are assembled and up, cut braces and intermediates.
- Cut 160 each 3" Dexion steel brackets from leftover scraps.
- Two (2) packs will be required for intermediates.
- Two (2) packs will be required for underside braces.

WOOD BLOCKS

- There are wood blocks 6" x 6" (also known as pads) placed at the bottom of all Intermediates and Uprights and two (2) under each track section in the infield where Dexion metal comes in contact with the floor surface.
 - a. 80 each – Under track sections in infield.
 - b. 40 each – Bottom of each Upright.
 - c. 40 each – Bottom of each Intermediate.

TOTAL 160 each

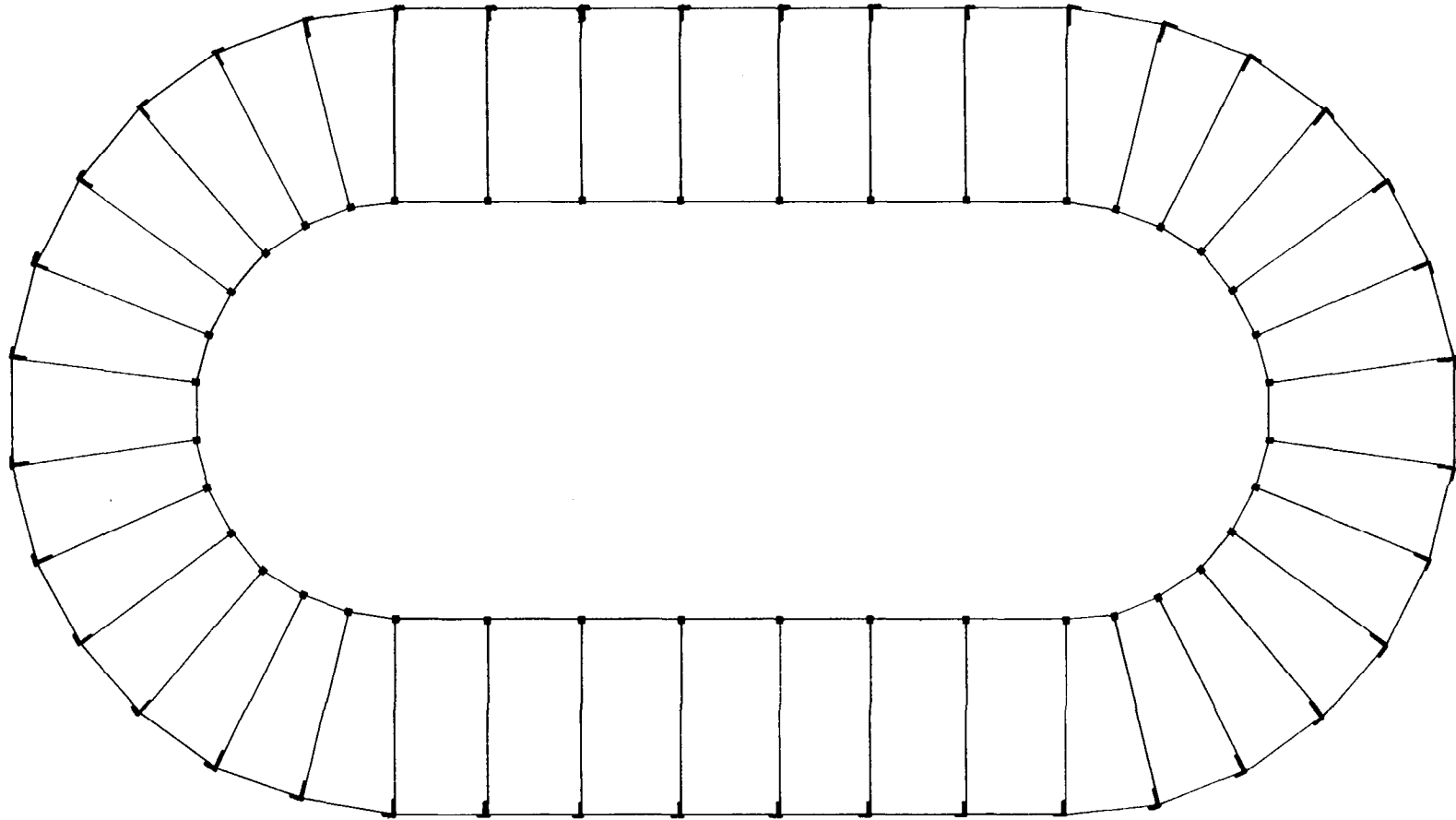

**LOCATION OF
WOOD PADS & UPRIGHTS**

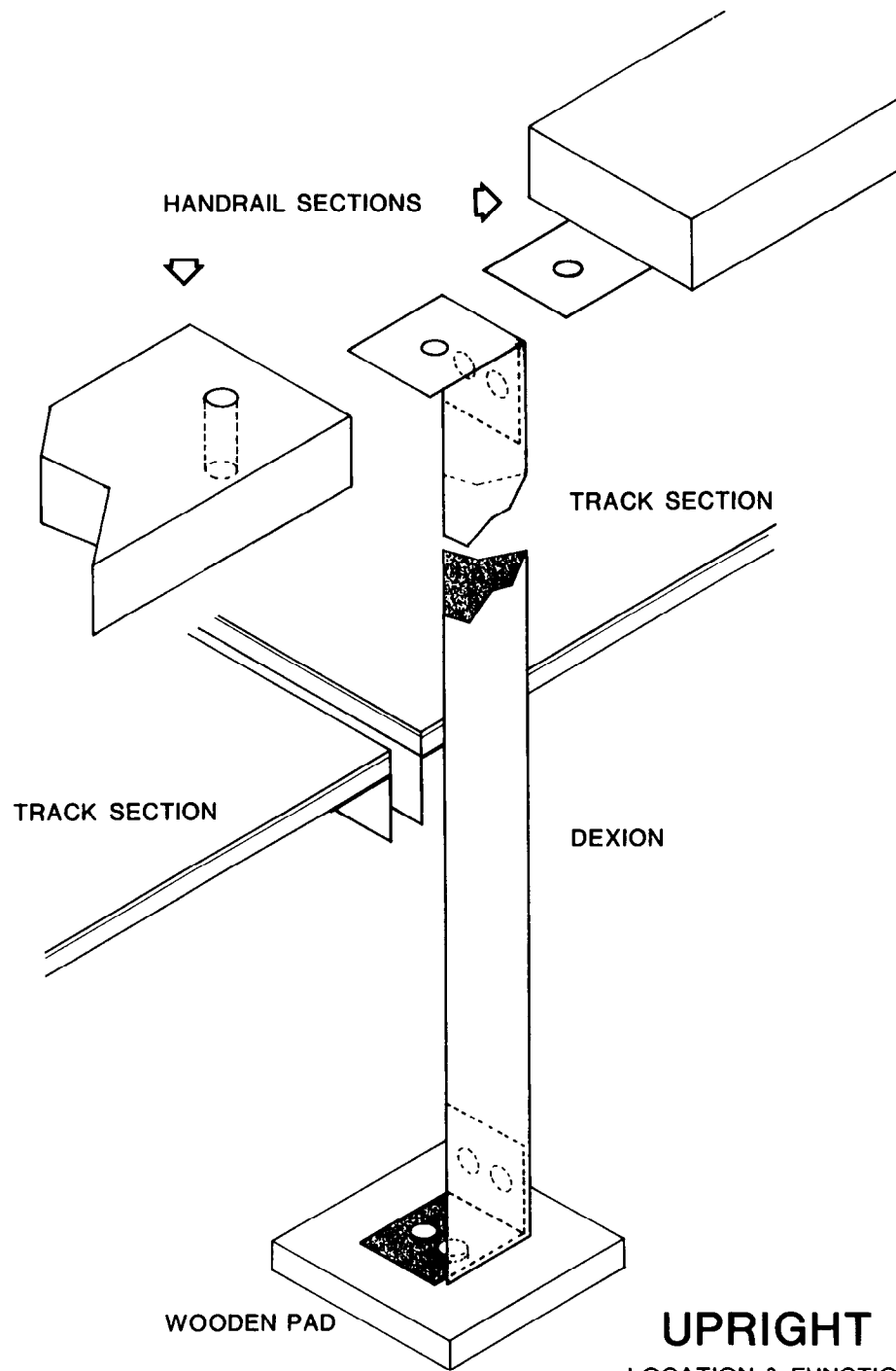

UPRIGHT
LOCATION & FUNCTION

PADS FOR HANDRAILS and UPRIGHTS

VINYL

Reinforced P.V.C. Herculite Vinyl/Nylon-Coated Material comes in 50" – 54" – 60" width by 50 yard rolls.

Uprights require – 1 each – 50 foot roll.
Handrails require – 2 each – 50 foot rolls.

Note:

If two colors are required – there will be NO COST BREAK. Rolls will not be split.

FOAM

Glued to bottom side of covers.
Handrails – cut foam to 1" x 9" x 72" – 40 each.
Uprights – cut foam to 1" x 9" x 30" – 40 each.

VELCRO

50 yards of 2" width male/female. One on bottom, the other on top of all handrails and upright pads.

METAL STRAPS

May be used, but NOT RECOMMENDED.

CENTER BOLTS

Used in connecting two track sections. Located midway and underneath track seams.

WOOD BLOCKS

Placed along the inside line, under steel on floor, where track sections connect.

UPRIGHTS

Located along the outside perimeter of the track, where track sections connect.

BRACES

All Uprights will require braces in various lengths.

SUPPORTS

Located underneath and attached to the center piece of twelve foot Dexion. Three feet in from the outer perimeter of track.

KICK – RAILS

Located at the outer perimeter of track on the Skating Surface, will be attached with bolts. Made from 2" x 4" x 5' 8" between Uprights.

HAND – RAILS

Rest on a bracket located at the top of each Upright and connect all three with a bolt.

MASONITE

- (a) Permanent Masonite is located in the center of all track sections. This permanent Masonite is only removed from the track surface if severely damaged or being re-surfaced with new Masonite.
- (b) Temporary Masonite is located between permanent Masonite, to complete a smooth skating surface. These pieces of Masonite cover theseams where track sections meet and connect. These temporary pieces are the last to be put in place when assembling the track and the first to be removed when disassembling for transporting. Thirty-two (32) screws per section.

PADS

- (a) Uprights will be fitted firsts with Pads placed between kickrail and handrails.
- (b) Handrails will be fitted last, to assure a smooth overlapping seam, where the uprights and handrails connect.
- (c) These handrail pads can be started at any point on the track. All pads must be placed in a COUNTER-CLOCKWISE direction to allow for overlapping.

SET-UP

Begin your set-up at section number ten (10) and proceed in a COUNTER-CLOCKWISE direction until completed.

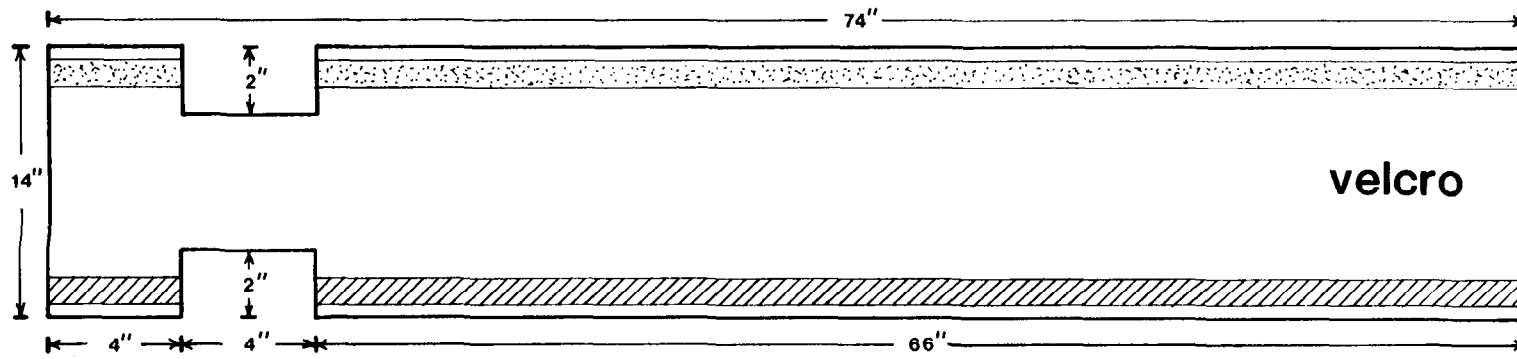

Handrail

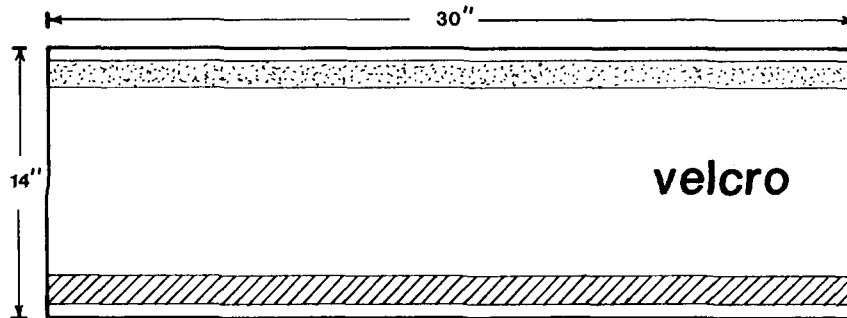

Upright

PADS

LOADING TRACK ON TRUCK

FIRST STEP

- Track sections to be loaded first. Start by loading the first two track sections on either side of the Bastard Piece.
- These first two sections are to be stacked METAL TO METAL – the next two sections (again one from either side of the Bastard Piece) will be placed MASONITE TO MASONITE, etc, etc, etc.
- The two Bastards are the last sections to be loaded.

SECOND STEP

- Load Handrails.

THIRD STEP

- Load Uprights.

FOURTH STEP

- Load Intermediates.

FIFTH STEP

- Load box with Wood Blocks.

SIXTH STEP

- Load Penalty Boxes.

SEVENTH STEP

- Load Handrail Pads.

EIGHTH STEP

- Load Upright Pads.

NINTH STEP

- Load Tarpaulin.

NOTE:

- All track sections (turns and straight-aways) will be placed on their sides in the trailers when loading.
- A twenty-six (26') foot trailer is the minimum length to be used – or – two sixteen (16') foot Bob Tails.

IMPORTANT

UN-LOADING IS ACCOMPLISHED BY REVERSING THE LOADING PROCEDURE

LOADED Truck or Trailer

Rear View

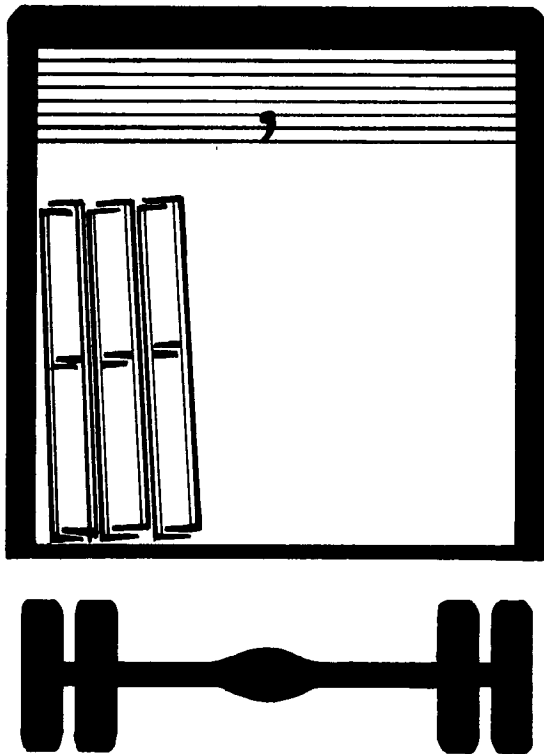

Top View

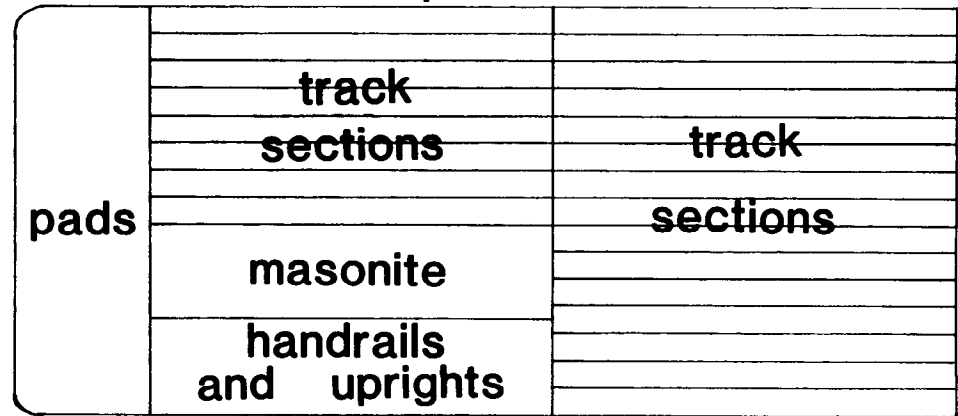

Side View

